

Newflow

Pico RMU

**Incorporating
TorqueWrench**

**User
Manual**

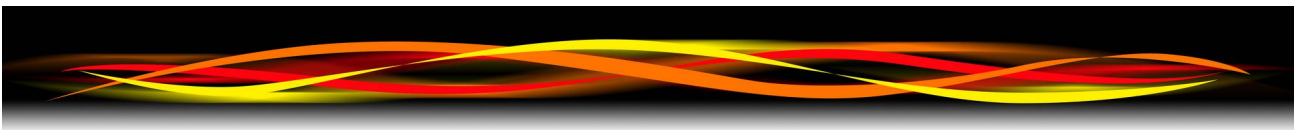



Contact:

Newflow Ltd
George House
Derwent Road
Malton, North Yorkshire
YO17 6YB, UK

Tel: +44 1653 310 000
Email: sales@newflow.co.uk

Document Information

Document Name	Pico RMU User Manual
Document Identifier	PicoRMU-UM

NANO (with Angstrom symbol) and Visual C||Cure are registered trademarks of Newflow Ltd.

All trademarks are acknowledged as the property of their respective owners.

TESTit & PROVEit are trademarks of Quorum Business Solutions, Inc. (Flow-Cal, Inc).

This document, submitted in confidence, contains proprietary information and shall not be reproduced or transferred to others without prior written permission of Newflow Ltd.

This document shall not form part of any contract. Specifications are subject to change without notice and Newflow Ltd accepts no liability of any kind for errors or omissions.

Full contractual terms are available on the website at www.newflow.co.uk/pdf/tandc.pdf

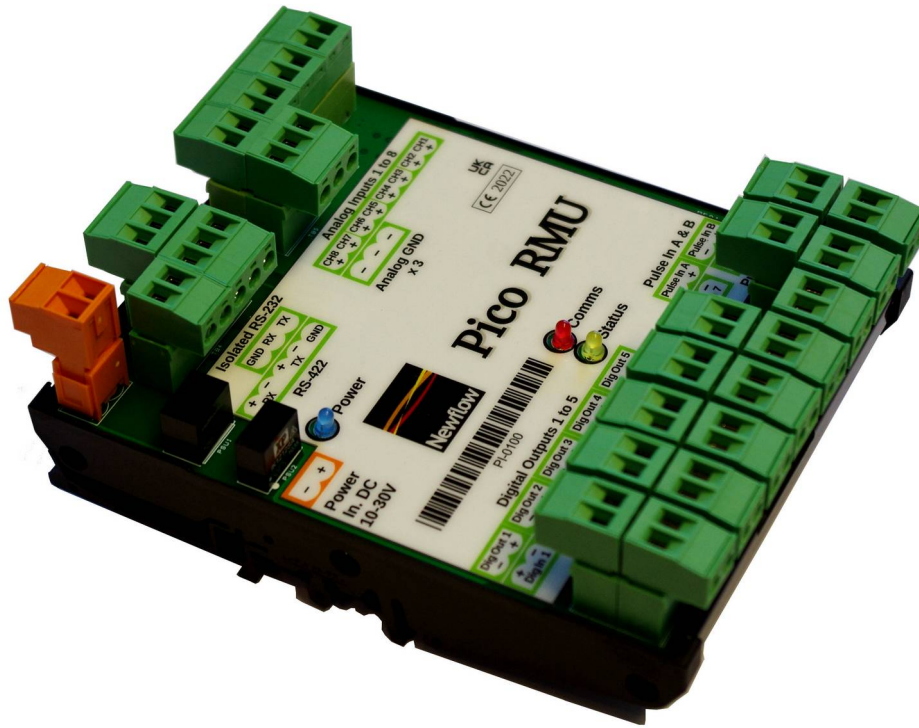

Table of Contents

1	Introduction	5
2	Pico RMU I/O	6
2.1	Field I/O	6
2.2	Communications	7
2.3	Input Power	7
2.4	Digital Inputs	7
2.4.1	Digital Input Circuit Overview	7
2.4.2	Digital Input Functional Representation	7
2.4.3	Digital Input Field Wiring Example	8
2.5	Digital Outputs	9
2.5.1	Digital Output Circuit Overview	9
2.5.2	Digital Output Functional Representation	9
2.5.3	Digital Output Field Wiring Example	10
2.6	Pulse Inputs	11
2.7	4-20mA High Accuracy 24bit Analog Inputs	11
2.7.1	Analog Input Block Diagram	12
2.7.2	Analog Input Field Wiring	13
3	Pico RMU in RTU Mode	14
3.1	RTU Mode Connection Pinout Drawing	14
4	Pico RMU in PIU Mode	15
4.1	PIU Mode Connection Pinout Drawing	15
4.2	Digital Input Assignment	16
4.3	Digital Output Assignment	17
5	TorqueWrench	18
5.1	PicoRMU Info Page Information	19
5.1.1	Pulse Inputs	19
5.1.2	Device Information	19
5.1.3	Digital Inputs	19
5.1.4	Digital Outputs	20
5.1.5	Analog Inputs	20
5.1.6	Pressure Correction	20
5.2	PicoRMU Config Page Information	21
5.2.1	Digital Input Inversion	21
5.2.2	Digital Output Inversion	21
5.2.3	RS422/485 Config	22
5.2.4	Fwd/Rev Timeout (secs) – PIU Mode Only	22
5.2.5	Modbus Slave Address	22
5.2.6	Densitometer Pressure Compensation	22
5.3	PicoRMU Info Page in PIU Mode	23
5.4	Wiring the Isolated RS422 Converter	24
6	Modbus	25
6.1	Modbus Slave Map	25
6.1.1	INT16 Addresses	26
6.1.2	INT32 Addresses	27
6.1.3	FLOAT32 Addresses	28
6.2	Newflow Modbus Master Simulator	29
7	Mechanical Dimensions	30
8	Specifications	31
8.1	Mechanical	31
8.1.1	DIN Rail Mounted	31
8.1.2	Potted Unit	31
8.2	Environmental	31
8.3	Power Supply	31
8.4	Digital Status Inputs	32
8.5	Digital Status Outputs	32
8.6	Meter Pulse Inputs & Period Measurement	32
8.7	Analog Inputs	32
9	Revision History	33

Operational Overview

The Pico RMU is a small footprint Remote Measurement Unit optimized for flow measurement and meter proving applications.

Features

The Pico RMU is designed to operate as an interface to the Quorum (previously Flow-Cal, Inc) TESTit & PROVEit validation packages. The following features are included as part of the design of the unit:

- Packaged in either a DIN Rail mounting enclosure, or as a fully potted version for tough environmental locations.
- All connections are made by pluggable heavy duty 5mm terminal blocks. These can accept cable of 24AWG to 12AWG.
- Operating temperature range is -40 °F to +185 °F.
- Compatible TESTit & PROVEit RS232 serial interface.
- RS232 port is optically isolated from the internal ground, shared by the analog inputs, to ensure there are no ground loops which could affect the integrity of operation.
- RS422 port can also be used with TESTit & PROVEit if longer cable lengths are required.
- Digital inputs, digital outputs and pulse inputs are all individually optically isolated.
- The Pico RMU can also be used as a general purpose RTU device, communicating via Modbus RTU protocol.
- Modbus Master interface provided for connection to a densitometer or Coriolis meter. This allows the Pico RMU to provide the line pressure to the densitometer or Coriolis meter so that it can enhance accuracy by correcting the measured density for the effects that pressure has on the tube stiffness. This runs on the RS-422/485 serial port.
- A Poll Profile File for the Pico RMU is available for the Newflow Modbus Master Simulator. This allows the Pico RMU to be verified in Modbus mode.
- The free of charge TorqueWrench Windows program can also be used for diagnostic and configuration purposes.

2 Pico RMU I/O

2.1 Field I/O

The Pico RMU has the following Field I/O available:

Field I/O Type	Number of Channels	Pins Used	Isolated	Use or Comment
Meter Pulse Inputs see 2.6 - Pulse Inputs	3	6	Yes	All inputs have high resolution period measurement and are also suitable for use with a Densitometer
Digital I/P see 2.4.- Digital Inputs	7	14	Yes	Digital Input 7 is also used as the Detector/Sphere-Switch input
Digital O/P see 2.5 - Digital Outputs	5	10	Yes	General Purpose, protected Outputs with low saturation, can drive TTL
Analog Inputs see 2.7 - 4-20mA High Accuracy 24bit Analog Inputs	8	8+3	No	The eight inputs are configured for 4-20mA, sharing a common ground
RS232	1	3	Yes	PROVEit/TESTit Interface or Modbus RTU
RS422 or RS485	1	5	No	Modbus RTU slave Interface or Modbus Master Interface

To avoid ground loops whilst using the RS422 port, the use of an isolated RS422 converter is recommended, see [5.4 - Wiring the Isolated RS422 Converter](#).

2.2 Communications

The Pico RMU is equipped with two serial communications ports. One port is an optically isolated RS232 port intended for direct connection to the Quorum (previously Flow-Cal, Inc) PROVEit and TESTit proving supervisory programs. If the Pico RMU is not being used with PROVEit, the port is a slave Modbus RTU link.

The second port is an RS422 port. With full control provided on the enable signals for both the transmit and receive, the port can also be used in RS485 mode, by connecting the RX+ & TX+ together to produce the RS485 A signal and connect the RX- & TX- together to produce the RS485 B signal.

The RS232 port is fixed as 9600, 8 data bits, 1 stop bit, No Parity

The RS422 port is defaults to 57600, 8 data bits, 1 stop bit, No Parity

2.3 Input Power

The Pico RMU will operate with a supply voltage in the range of 10V to 30V. It consumes around 0.25W, and runs very cool to maximize lifetime and reliability.

2.4 Digital Inputs

There are seven identical high impedance optically isolated Digital Input channels. Each channel has both surge and reverse voltage protection, the input circuit is shown below. Following recovery of the signal from the opto-isolator, the signal is fed into the Processor (CPU) where it is digitally processed.

2.4.1 Digital Input Circuit Overview

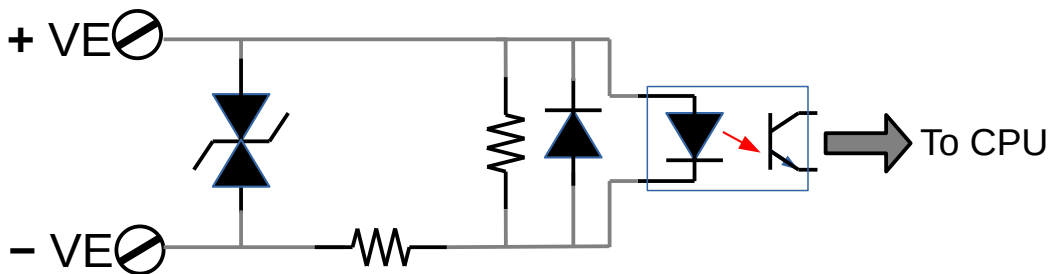

2.4.2 Digital Input Functional Representation

From an operation perspective, each digital input can be considered as a light bulb with a series diode. The voltage must be applied in the right polarity but, because they are all individually isolated, the installer has the freedom to connect them in a number of ways.

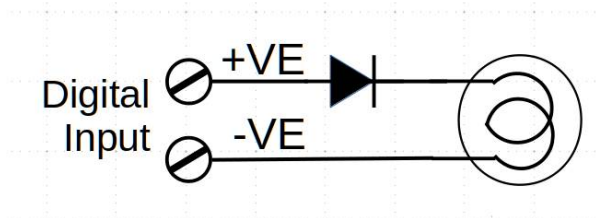

A digital input is active when a voltage of the correct polarity is connected between the two input connections and the "light bulb" is illuminated

2.4.3 Digital Input Field Wiring Example

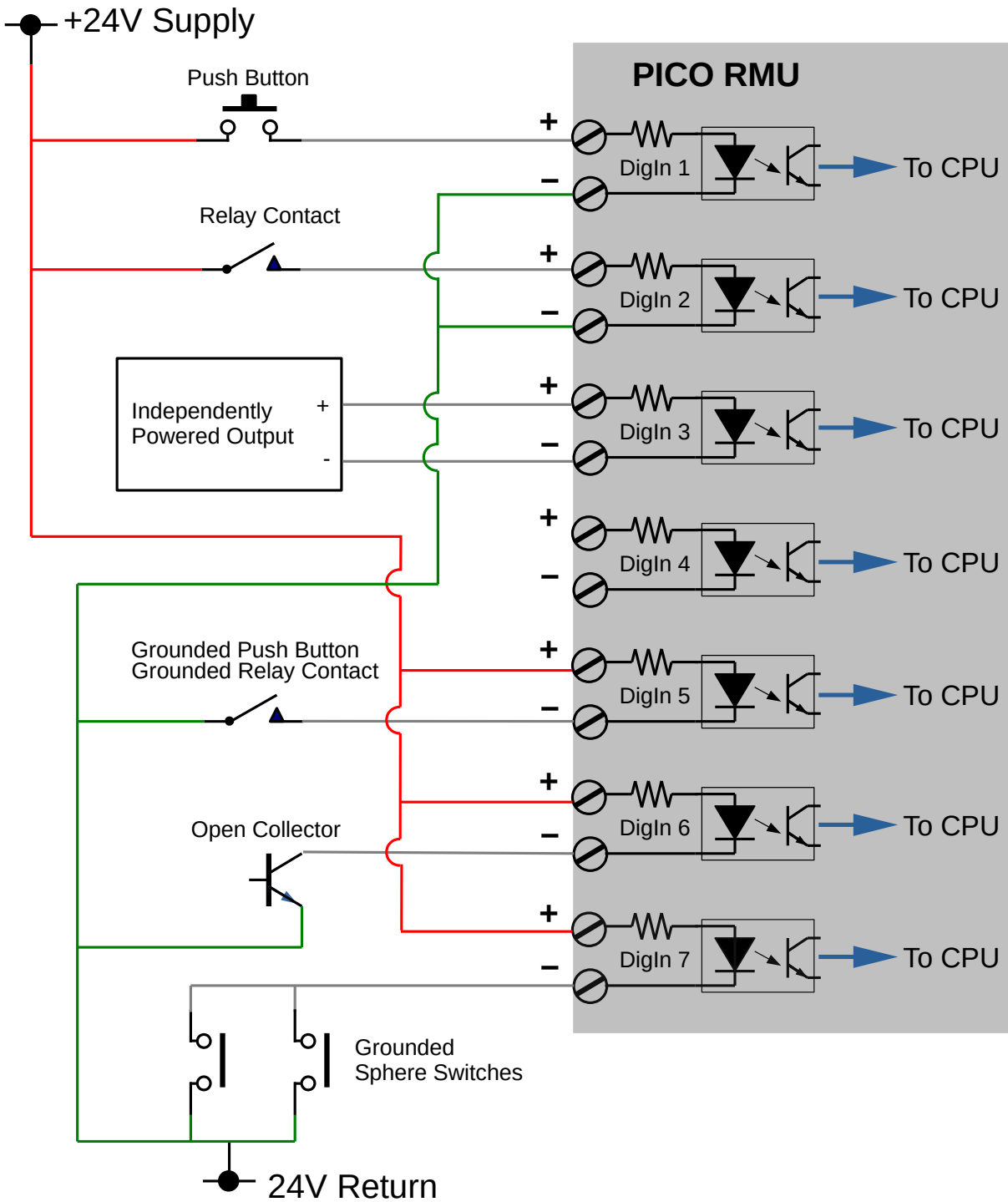

2.5 Digital Outputs

There are five Digital Outputs provided. Each output channel has a high current output which is surge and reverse connection protected. Each output is optically isolated from all other I/O points. This allows it to be connected to either the positive rail to act as a current source or connected to the negative rail to mimic a grounded open collector output.

Each output also has a highly robust protection circuit that disconnects the load in case of an accidental overload.

2.5.1 Digital Output Circuit Overview

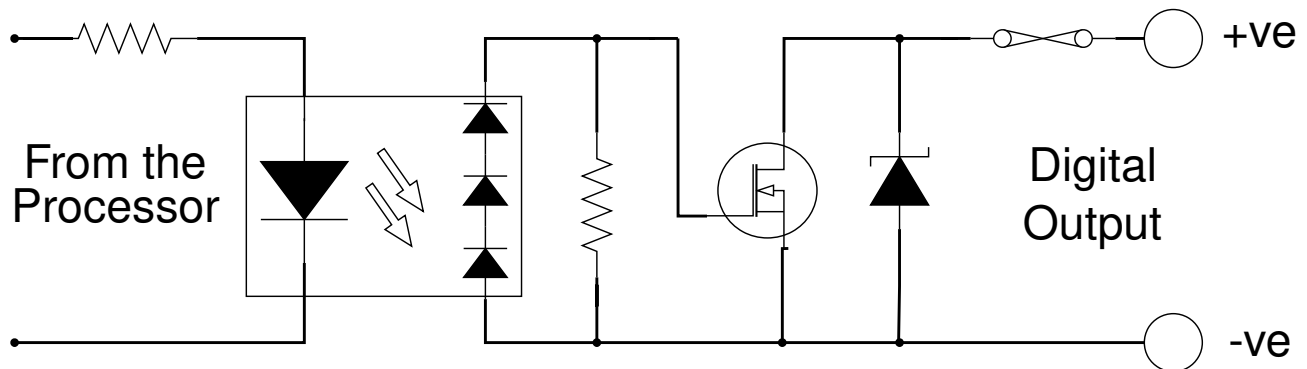

2.5.2 Digital Output Functional Representation

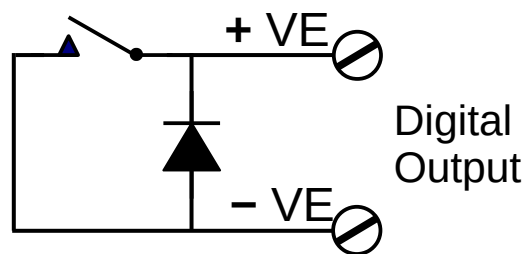

Each digital output can be considered as the contacts of a relay with a reverse clamp diode.

When the digital output is **OPEN**, no current will flow from the +ve to the -ve terminals (as long as the correct polarity is observed). When the contacts are **CLOSED**, current will flow.

NOTE: The protection device on the Digital Outputs will make current flow if the polarity is reversed regardless of whether the Pico RMU is powered on or turned off.

2.5.3 Digital Output Field Wiring Example

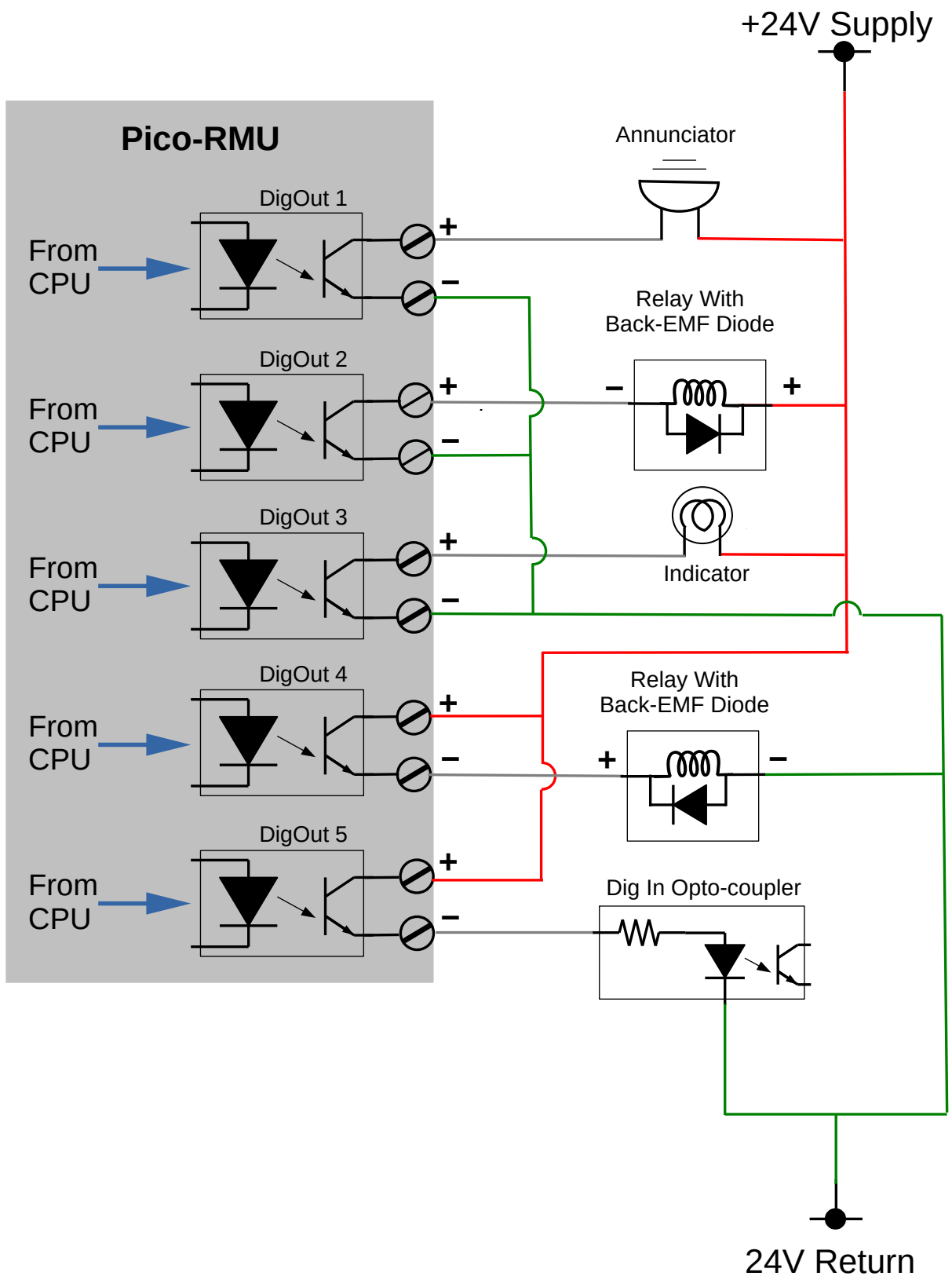

2.6 Pulse Inputs

There are three Pulse Input channels. Each is individually opto-isolated and has transient protection and filtering. They are suitable for meter pulses or frequency mode Densitometers, as all inputs have high resolution period measurement suitable for use with Densitometers.

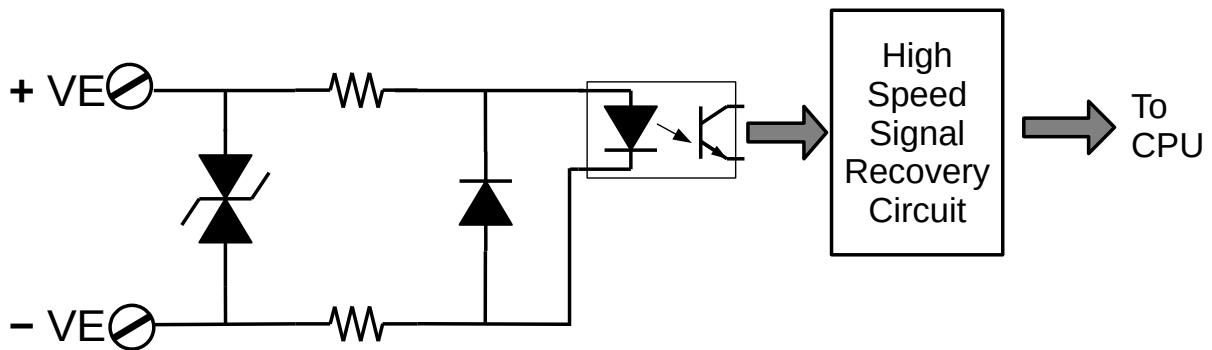

2.7 4-20mA High Accuracy 24bit Analog Inputs

The Analog section provides eight identical, high accuracy Analog Input measurement circuits, sharing a common ground. They are all 4-20 mA measurement channels.

24bit sigma-delta Analog to Digital Converter (ADC) technology is used together with a precision reference.

2.7.1 Analog Input Block Diagram

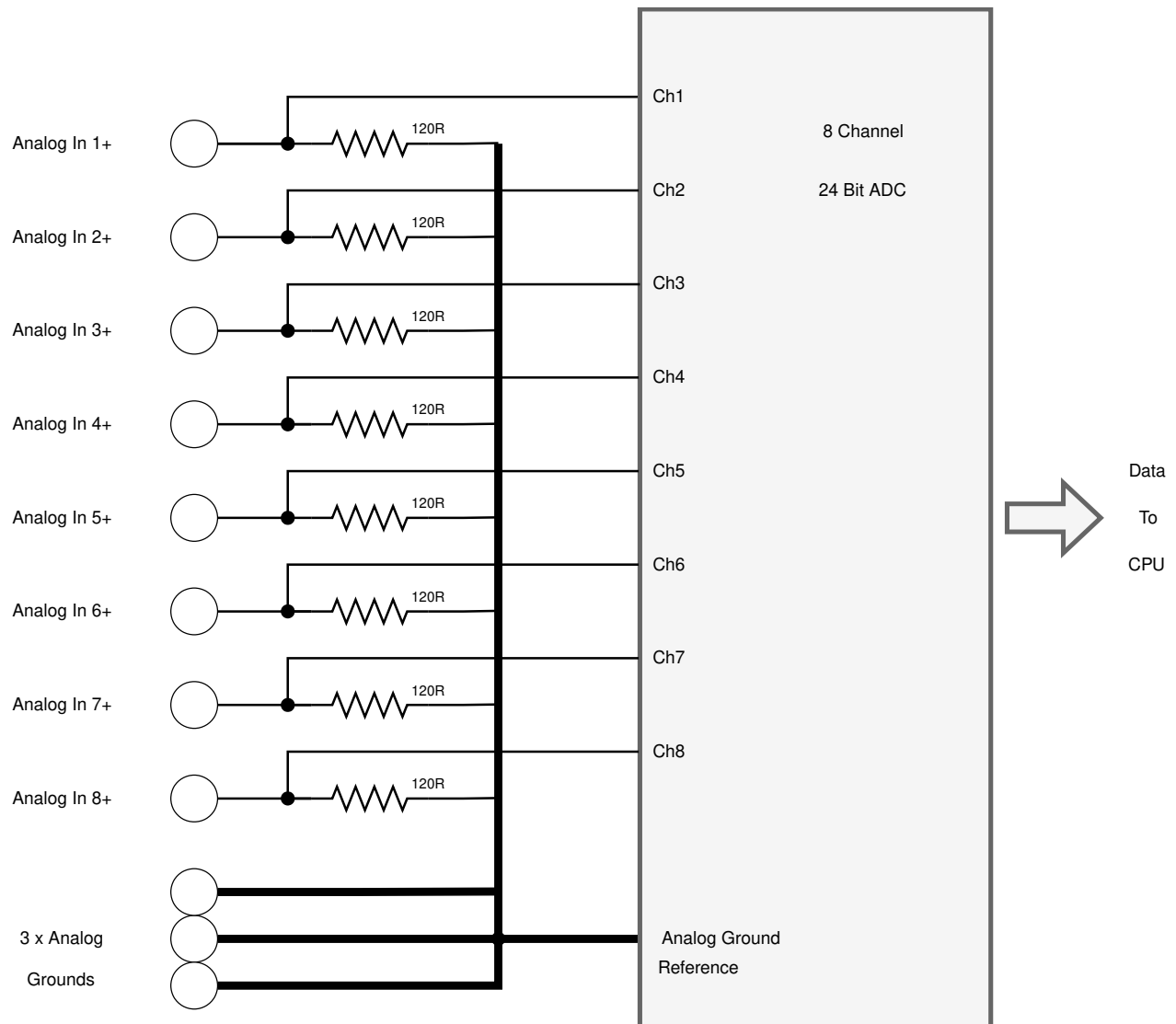

2.7.2 Analog Input Field Wiring

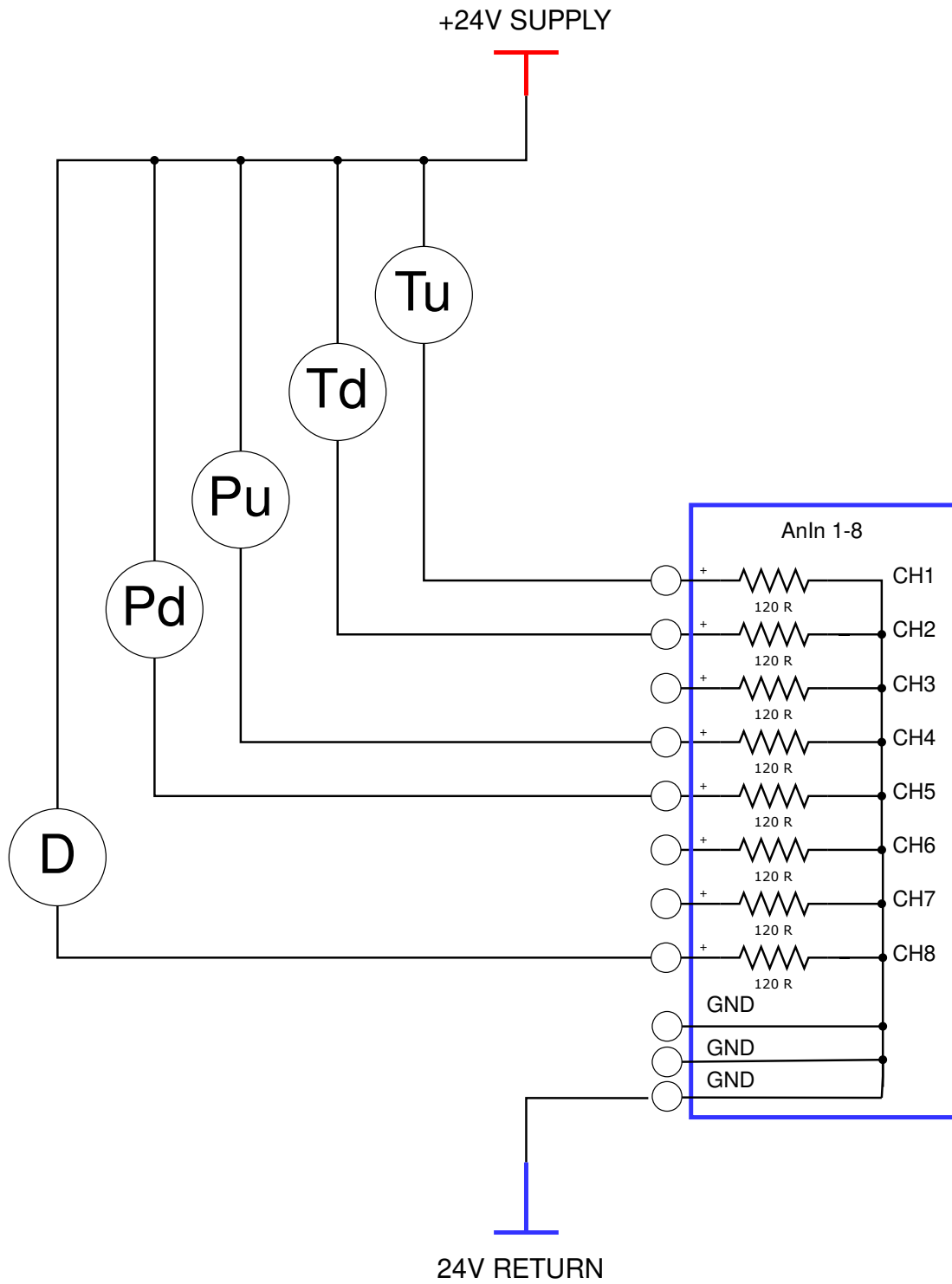

3 Pico RMU in RTU Mode

3.1 RTU Mode Connection Pinout Drawing

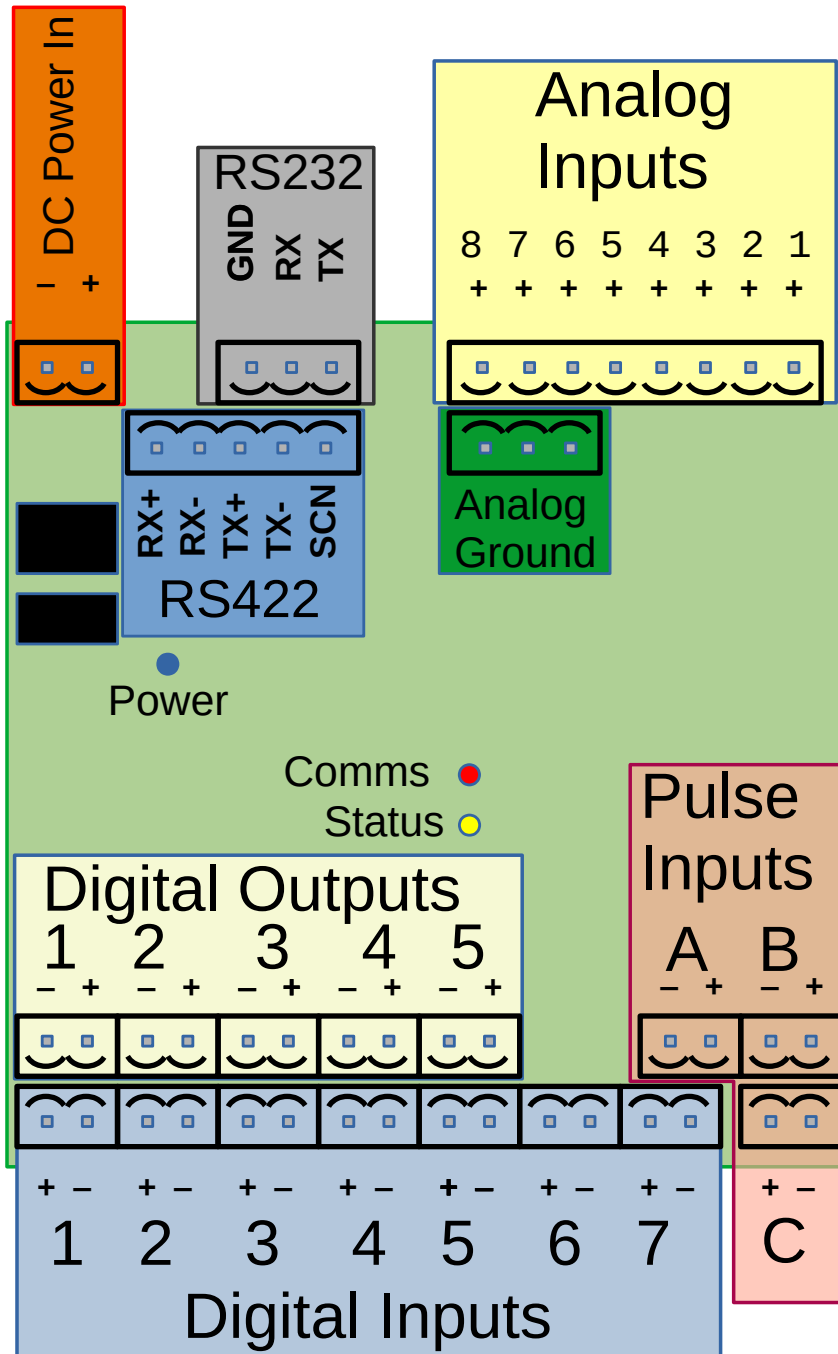

4 Pico RMU in PIU Mode

When the Pico RMU detects PIU formatted commands are being received, rather than Modbus polls, it automatically switches into PIU operational mode.

4.1 PIU Mode Connection Pinout Drawing

PIU MODE Digital Inputs & Outputs

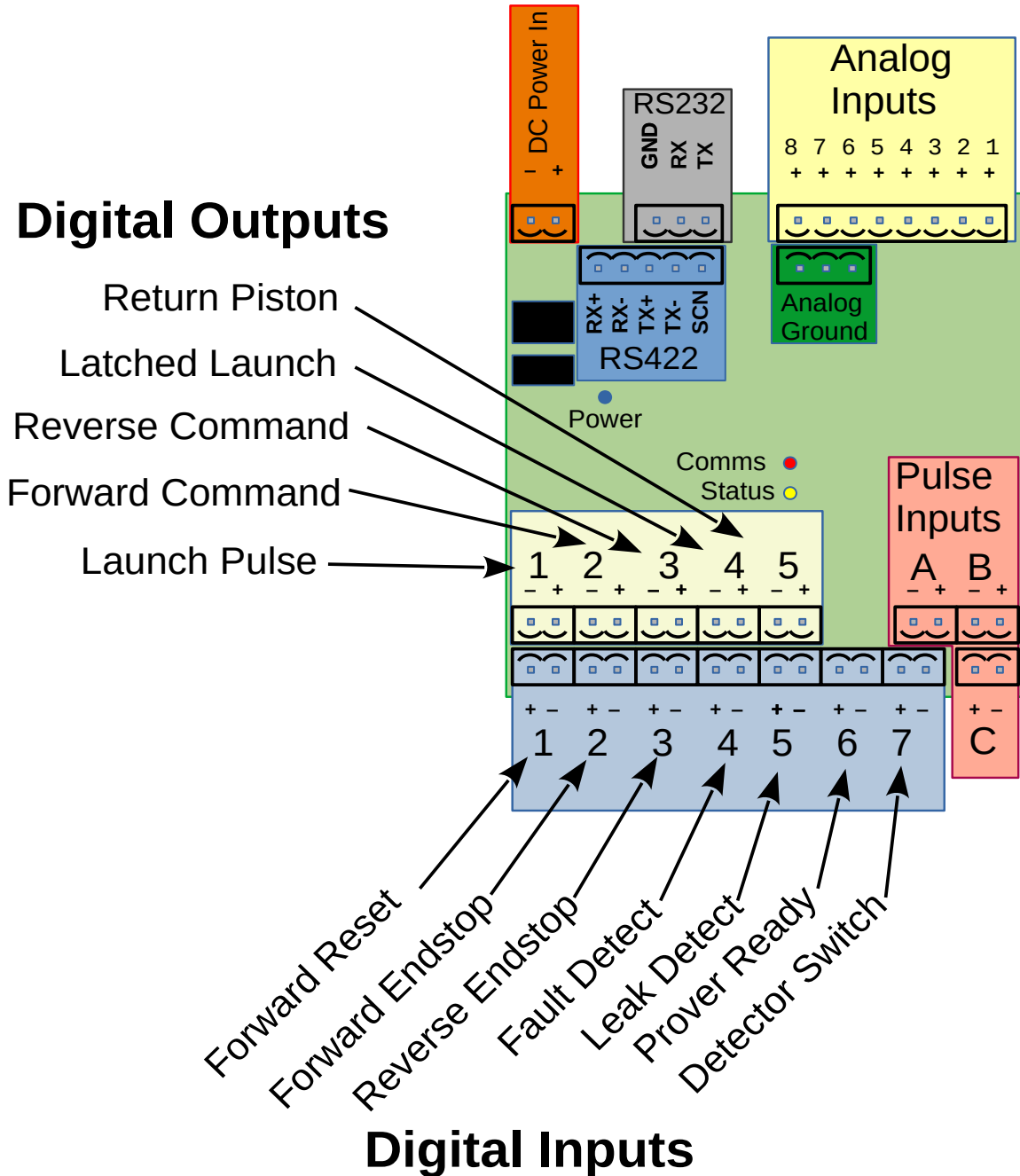

In PIU mode, the functions of the Digital Inputs and Digital Outputs are pre-selected as shown on the previous page. The selection of the Pulse Input channel and the Analog Input channels can be chosen within PROVEit.

The connection to the PC running the prover software package usually utilizes the RS232 link, and the baud rate and other serial communications settings are fixed. For installations that need longer cables or better noise immunity, the RS422 port can be used for the PIU communications as long as it is configured to 9600 baud to match the setting of PROVEit.

The spare serial communications port can be used for two purposes:

1. It can be used with TorqueWrench to check or diagnose any problems with the field connections as it gives a clear indication of the current status of all of the inputs and outputs.
2. It can also be used to configure the Pico RMU options, such as inverting any or all of the Digital Inputs & Digital Outputs, selecting a Forward and Reverse command timeout for the 4-way valve in Bi-Directional prover mode or configuring the Densitometer pressure correction.

4.2 Digital Input Assignment

In PIU mode, the use of the Digital Inputs has been allocated as shown in the table below.

Digital Inputs	Description	PROVEit Function
DIGIN1	Forward Reset	This input resets the alternating Forward Command and Reverse Command outputs for the 4-way valve control, to the forward direction. This information is not transmitted to PROVEit.
DIGIN2	Forward Endstop	If the BiDi Prover 4-way valve has a switch to indicate the valve has completed its forward travel, it can be connected here.
DIGIN3	Reverse Endstop	If the BiDi Prover 4-way valve has a switch to indicate the valve has completed its reverse travel, it can be connected here.
DIGIN4	Fault Detect	The state of this input is transmitted directly to PROVEit.
DIGIN5	Leak Detect	The state of this input is transmitted directly to PROVEit.
DIGIN6	Prover Ready	The state of this input is transmitted directly to PROVEit.
DIGIN7	Detector Switch	Detector Switch also known as Volume Pulse The detector switch input is used to trigger the various internal counters and drives the prover sequence along.

4.3 Digital Output Assignment

In PIU mode, the use of the Digital Outputs has been allocated as shown in the table below.

Digital Outputs	Description	PROVEit Function
DIGOUT1	Launch Pulse	Launch (500ms duration pulse). This output is triggered directly by PROVEit. This output is used with mechanically driven Small Volume Provers.
DIGOUT2	Forward Command	The Forward Command and Reverse Command outputs are triggered alternatively by the PROVEit Launch request. These are intended for use with bi-directional provers. The Forward or Reverse Command signals stay active until either the associated Endstop input signal is detected or the Prover FWD/REV Timeout is exceeded.
DIGOUT3	Reverse Command	Reverse Command for bi-directional provers. See Forward Command above.
DIGOUT4	Latched Launch	This output is used with hydraulically driven Small Volume Provers. The Latched Launch output will stay active until the second detector has been triggered.
DIGOUT5	Return Piston	Return Piston (500ms duration). This output is triggered directly by PROVEit.

5 TorqueWrench

The TorqueWrench Windows program can be used to check the installation and that appropriate values are being seen. In addition, the Config tab allows the digital inputs and digital outputs to be inverted. These settings are stored in non-volatile memory, so will be remembered after a power cycle.

The TorqueWrench program is a single executable program and does not require an installer as it requires no other files to operate.

The file can be placed in any folder or directory, including the desktop, a USB memory stick or a network drive. When the program is first launched, it will create a TorqueWrench.ini file in the same directory as the executable is run from. This file stores information such as the serial port settings.

TorqueWrench communicates with the Pico RMU by means of Modbus RTU only.

The screenshot directly below shows the screen after launching the application. The initial view displays the Pico RMU Information page (PicoRMU Info).

TorqueWrench - v1.0.6.1

File Comms

PicoRMU Info PicoRMU Config

	Frequency (Hz)	Pulse Count		
Channel A	11111.1	13099899	S/No	9104FE-624DF4
Channel B	750.056	884309	Version [CRC]	1v00r07 [2573]
Channel C	0.00000	0	Tick ms	1179118
			Pkt Count	5901
			Update Count	1180
			RMU Temperature	79.9 °F

DigIns		DigOuts
ON-HI	Ch1	OPEN
OFF-LO	Ch2	CLOSED
ON-HI	Ch3	CLOSED
OFF-LO	Ch4	OPEN
OFF-LO	Ch5	OPEN
OFF-HI	Ch6	
ON-LO	Ch7	

	Analogs (mA)
Ch1	0.0000
Ch2	13.2671
Ch3	13.2633
Ch4	13.2632
Ch5	13.2682
Ch6	0.0000
Ch7	0.0000
Ch8	0.0000

Pressure Correction

57.919

5.1 PicoRMU Info Page Information

The following describes in more detail the information shown on the PicoRMU Info screen on the previous page.

5.1.1 Pulse Inputs

The top left of the screen shows the frequency to 6 significant digits for the three pulse input channels. It also displays the Pulse Count of each channel since the Pico RMU was powered on.

5.1.2 Device Information

The top right of the screen has six information fields. These are:

1. S/No The Pico RMU unique Serial Number
2. Version [CRC] This is the firmware version with the checksum in square brackets
3. Tick ms This is the Pico RMU up-time in milliseconds
4. Pkt Count This shows the number of Modbus messages decoded by TorqueWrench
5. Update Count This indicate the number of updates to all eight Analog Inputs
6. RMU Temperature This is the internal temperature of the ADC voltage reference

5.1.3 Digital Inputs

The center left of the screen shows a mimic of the status for each of the Digital Inputs, Ch1 to Ch7.

These seven fields display two pieces of information for each digital input.

The first word (OFF or ON) shows the electrical levels going into the digital input circuit, and indicates if the "light bulb" is turned on or off.

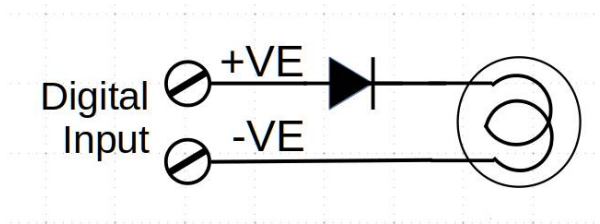

A digital input is OFF unless a voltage of the correct polarity is connected between the two input connections. Then the "light bulb" would be illuminated and the input would report ON.

The second word (LO or HI) shows the input logic state following the Digital Input Invert function for each channel described in section [5.2.1 - Digital Input Inversion](#).

Input Level	No Inversion	Inversion Selected
Input Off: less than 1.5V across the terminals	OFF-LO	OFF-HI
Input On: more than 5V across the terminals	ON-HI	ON-LO

5.1.4 Digital Outputs

The middle of the screen shows a mimic of the status for each of the Digital Outputs, Ch1 to Ch5.

These five fields show the commanded value sent to the Digital Output Circuitry. The actual output may be opposite the software value, if the Digital Output Invert function has been enabled for that channel.

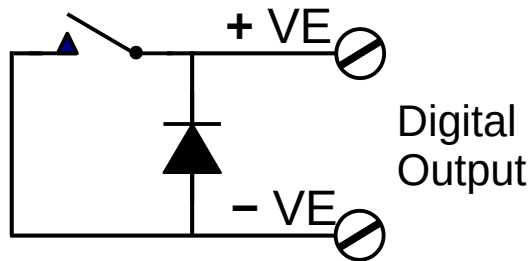

When the digital output is **OPEN** no current will flow from the +ve to the -ve terminals. When the contacts are **CLOSED**, current will flow as long as the correct polarity is observed.

NOTE:

The protection device on the Digital Outputs will make current flow if the polarity is reversed regardless of whether the Pico RMU is powered on or turned off

5.1.5 Analog Inputs

The center right of the screen shows the Analog Input current, measured in milli-amps (mA) for each of the eight channels Ch1-Ch8, shown to 4 decimal places.

5.1.6 Pressure Correction

The bottom right of the screen has a single data field titled Pressure Correction.

The figure displayed is calculated by applying the scaling values (the pressure @ 4 mA and 20 mA) to the analog reading of the selected channel, as shown in the PicoRMU Config screen described in [5.2.6 - Densitometer Pressure Compensation](#).

This calculated value can be transmitted to a Densitometer or Coriolis meter so the meter can correct its density measurement due to the effects of pressure on the measuring tube stiffness.

5.2 PicoRMU Config Page Information

Clicking on the PicoRMU Config tab will show the configuration features available.

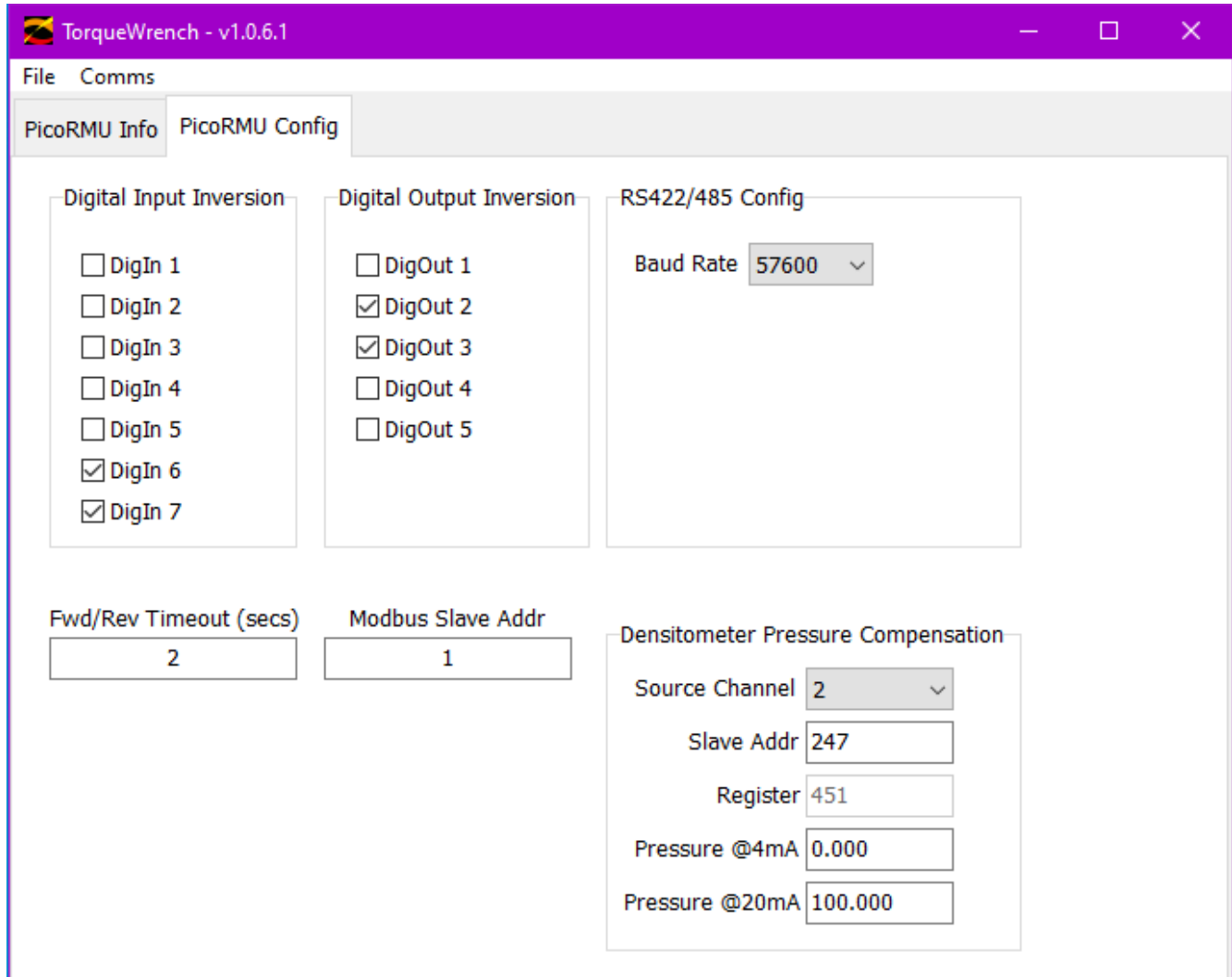

5.2.1 Digital Input Inversion

In the PicoRMU Config screenshot, on the top left hand side, the tick indicates that the corresponding input is inverted. In the example, Digital Input 6 (DigIn6) and Digital Input 7 (DigIn7) are inverted, but the others are not.

5.2.2 Digital Output Inversion

In the PicoRMU Config screenshot, in the top center, a tick indicates that the corresponding output is inverted. In the example, Digital Output 2 (DigOut2) & Digital Output 3 (DigOut3) are inverted, but the others are not.

NOTE: Inverted Digital Outputs will be off when the Pico RMU is powered off and remain off when the Pico RMU is powered on. They will only change state when commanded by the Modbus or PIU communications.

5.2.3 RS422/485 Config

In the PicoRMU Config screenshot, on the top right hand side, the baud rate can be changed.

NOTE: TorqueWrench will automatically adjust to any baud rate changes, but there may be a delay of several seconds to restore communications.

5.2.4 Fwd/Rev Timeout (secs) – PIU Mode Only

In the PicoRMU Config screenshot, on the bottom left hand side, this timeout will disable the Forward (or Reverse) Command Digital Output after the timeout number of seconds, even if the Forward (or Reverse) EndStop Digital Input has NOT been seen.

It can be used to ensure the 4-way diverter valve motor is not driven continuously if an EndStop switch fails. In the absence of an EndStop input, it can be used to generate a pulsed output.

5.2.5 Modbus Slave Address

In the PicoRMU Config screenshot, in the bottom center, this allows the Modbus Slave Address to be set to the required value for the link. This can be set in the range of 1 to 254.

5.2.6 Densitometer Pressure Compensation

In the PicoRMU Config screenshot, on the bottom right hand side, these settings allow the pressure to be transmitted to the Densitometer or Coriolis meter so the meter can correct its density measurement due to the effects of pressure on the measuring tube stiffness.

Function Name	Description
Source Channel	Select the Analog Input channel that has the appropriate pressure.
Slave Address	This is the Modbus address of the Density Meter or Coriolis meter.
Register	This is the Modbus register. It is defaulted to 451, but can be changed.
Pressure @4mA	Set this to the pressure in the required units when the input to the Source Channel would be 4mA, 0% of scale.
Pressure @20mA	Set this to the pressure in the required units when the input to the Source Channel would be 20mA, 100% of scale.

5.3 PicoRMU Info Page in PIU Mode

The screenshot shows the TorqueWrench v1.0.6.1 software interface. The main window is titled "TorqueWrench - v1.0.6.1" and has a menu bar with "File" and "Comms". Below the menu bar, there are two tabs: "PicoRMU Info" (selected) and "PicoRMU Config".

The "PicoRMU Info" page displays the following data:

Frequency (Hz)		Pulse Count		S/No	
Channel A	500.000	1333995		276899-19803D	
Channel B	1000.06	2668140		Version [CRC]	1v00r07 [2573]
Channel C	0.00000	0		Tick ms	2668405
				Pkt Count	93
				Update Count	2669
				RMU Temperature	79.7 °F

DigIns		DigOuts		Analogs (mA)		
Fwd Reset	OFF-LO	Ch1	OPEN	Launch Pulse	Ch1	0.0000
Fwd Endstop	ON-HI	Ch2	OPEN	Fwd Command	Ch2	0.0000
Rev Endstop	OFF-LO	Ch3	OPEN	Rev Command	Ch3	5.6217
Fault Detect	OFF-LO	Ch4	CLOSED	Latched Launch	Ch4	6.5352
Leak Detect	OFF-LO	Ch5	OPEN	Return Piston	Ch5	4.6186
Prover Ready	ON-LO	Ch6			Ch6	7.2838
Detector switch	OFF-HI	Ch7			Ch7	6.4501
					Ch8	0.0000

Pressure Correction: Disabled

If serial data is received using the PIU protocol, TorqueWrench will add the labels for both the Digital Inputs and Digital Outputs, as shown in the screenshot above.

NOTE: The Analog Inputs are not labeled, since the channel assignment for Temperatures and Pressures etc is performed by PROVEit.

5.4 Wiring the Isolated RS422 Converter

For best analog performance when using the non-isolated RS422 port, the use of an isolated RS422 converter is recommended. See the hookup diagram below, using the DSD Tech SH-U11F USB to Serial Converter.

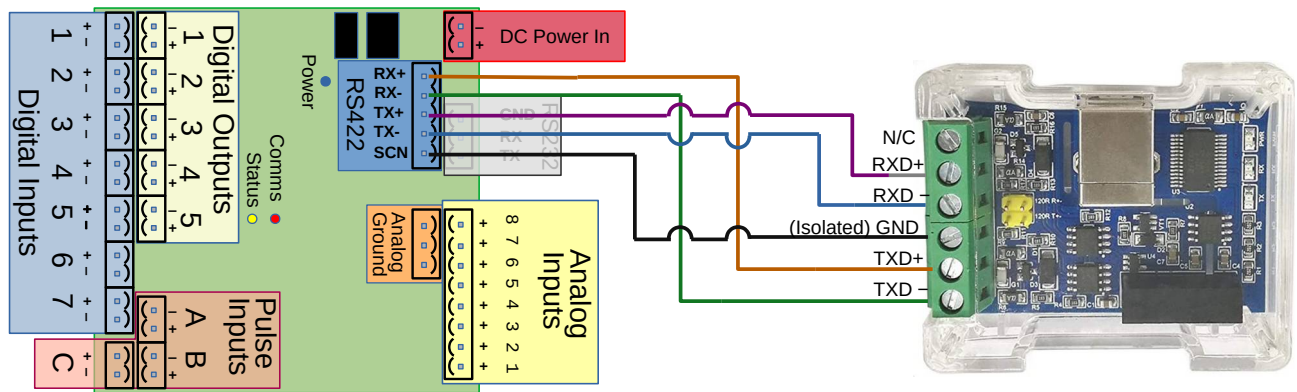

6 Modbus

6.1 Modbus Slave Map

The Pico RMU supports 3 different data formats;

- 16 bit Integer format (uint16, byte order 10)
- 32 bit Integer format (uint32, byte order 3210)
- 32 bit Float format (float32, IEEE-754, byte order 3210).

The data in 32bit Integer format is scaled to give sufficient resolution and allows the data to be "human" readable.

As it is a fully contiguous map, it allows all the data to be collected in a single poll.

Heading	Description
ATT	<ul style="list-style-type: none">• Read Only (RO)• Read and Write (RW)• Read and Write – Protected (RWP) The RWP attribute means that the location is protected. The correct code for the address must be written to the Modbus Write Lock (Address 1000) immediately beforehand.
NV?	Indicates if the RW value is stored in Non-Volatile memory, so will be remembered following a power cycle. A "YES" indicates that the value is stored.

6.1.1 INT16 Addresses

Modbus Address	Type	Description	ATT.	NV?	Range	Pre-Scaler &/Or Unit
1000	Int16	Modbus Write Lock – Note #1	RW	No	0 to 65,535	N/A
1001	Int16	Analog Poll Count – Note #2	RO	No	0 to 65,535	Not Scaled
1002	Int16	Digital Input Values (Bits: 0-6)	RO	No	0 to 127	Binary
1003	Int16	Digital Outputs (Bits: 0-4)	RW	No	0 to 31	Binary
1004	Int16	Invert Digital Inputs – Note #3	RWP	Yes	0 to 127	Binary
1005	Int16	Invert Digital Outputs	RWP	Yes	0 to 31	Binary
1006	Int16	Fwd/Rev Timeout – Note #4	RWP	Yes	0 to 65,534	millisec x 10
1006	Int16	MAC Address (Bits 0-15)	RO	No	0 to 65535	Binary
1008	Int16	MAC Address (Bits 16-31)	RO	No	0 to 65535	Binary
1009	Int16	MAC Address (Bits 32-47)	RO	No	0 to 65535	Binary
1010	Int16	Firmware Version	RO	No	0.00.00 to 6.55.35	BinaryModbus Master Simulator
1011	Int16	Firmware CRC	RO	No	0 to 65535	Binary
1012	Int16	Slave Address	RWP	Yes	1 to 254	Binary
1013	Int16	Special Function Codes	RW	No	Reserved	Reserved
1014	Int16	Densitometer Pressure Channel	RWP	Yes	1 to 8 (0=Disabled)	Binary
1015	Int16	Densitometer Slave Address	RWP	Yes	1 to 254	Binary
1016	Int16	Densitometer Pressure Register	RWP	Yes	0 to 65535	Binary
1017	Int16	RS422 Baud Rate – Note #5	RWP	Yes	1 to 7	Binary
1018	Int16	SS Debounce Period	RWP	Yes	0 to 65534	Milliseconds

Note 1 The Modbus write lock location 1000 must be written to immediately before writing to any of the protected locations, with the appropriate security code. Contact your local distributor for the security codes. All locations can be written to using TorqueWrench

Note 2 The analog poll count value is updated immediately after the new analog values are published.

Note 3 Bit 0 of the Digital Input Value (in both Int16 and Int32) represents Digital Input 1, bit 1 represents Digital Input 2 and so on. If you want to invert say Digital Input 2, then write 0100000 00000000 to the Invert Digital Input register immediately after writing the correct security code to the write lock location, or use TorqueWrench.

Note 4 This is only valid when using PROVEit. In RTU mode it has no function.

Note 5 RS422/485 Baud rate selection can be any of the following values:

- 1 = 2400 baud
- 2 = 4800 baud
- 3 = 9600 baud
- 4 = 19200 baud
- 5 = 38400 baud
- 6 = **57600 baud** (factory default)
- 7 = 115200 baud

6.1.2 INT32 Addresses

Modbus Address	Type	Description	ATT.	NV?	Range	Pre-Scaler &/Or Unit
1100	Int32	Version Number x.xx.xx	RO	No	0 to 65535	Not Scaled
1102	Int32	Comms Packet Count	RO	No		-
1104	Int32	RTU/PIU Mode	RO	No	1=RTU 2=PIU	Not Scaled
1106	Int32	Uptime Count in milliseconds	RO	No	0 to 4,294,967,295	Milliseconds
1108	Int32	Analog Poll Count	RO	No	0 to 4,294,967,295	Not Scaled
1110	Int32	Frequency Ch A	RO	No		Hz x 100,000
1112	Int32	Frequency Ch B	RO	No		Hz x 100,000
1114	Int32	Frequency Ch C	RO	No		Hz x 100,000
1116	Int32	Period C (ns)	RO	No		ms x 1,000,000
1118	Int32	Channel A Counts	RO	No	0 to 4,294,967,295	Binary
1120	Int32	Channel B Counts	RO	No	0 to 4,294,967,295	Binary
1122	Int32	Channel C Counts	RO	No	0 to 4,294,967,295	Binary
1124	Int32	Analog Input Ch 1	RO	No	0 to 25,000,000	mA x 1,000,000
1126	Int32	Analog Input Ch 2	RO	No	0 to 25,000,000	mA x 1,000,000
1128	Int32	Analog Input Ch 3	RO	No	0 to 25,000,000	mA x 1,000,000
1130	Int32	Analog Input Ch 4	RO	No	0 to 25,000,000	mA x 1,000,000
1132	Int32	Analog Input Ch 5	RO	No	0 to 25,000,000	mA x 1,000,000
1134	Int32	Analog Input Ch 6	RO	No	0 to 25,000,000	mA x 1,000,000
1136	Int32	Analog Input Ch 7	RO	No	0 to 25,000,000	mA x 1,000,000
1138	Int32	Analog Input Ch 8	RO	No	0 to 25,000,000	mA x 1,000,000
1140	Int32	Approximate Board Temperature	RO	No		°Celcius x100
1142	Int32	Digital Input Values (Bits: 0-6)	RO	No	0 to 127	Binary
1144	Int32	Digital Outputs (Bits: 0-4)	RW	No	0 to 31	Binary
1146	Int32	Invert Digital Inputs – Note #3	RWP	Yes	0 to 127	Binary
1148	Int32	Invert Digital Outputs	RWP	Yes	0 to 31	Binary

Note 3 Bit 0 of the Digital Input Value (in both Int16 and Int32) represents Digital Input 1, bit 1 represents Digital Input 2 and so on. If you want to invert say Digital Input 2, then write 0100000 00000000 to the Invert Digital Input register immediately after writing the correct security code to the write lock location, or use TorqueWrench.

6.1.3 FLOAT32 Addresses

Modbus Address	Type	Description	ATT.	NV?	Range	Pre-Scaler &/Or Unit
1200	Float32	Frequency Ch A	RO	No		Hz
1202	Float32	Frequency Ch B	RO	No		Hz
1204	Float32	Frequency Ch C	RO	No		Hz
1206	Float32	Period C μ s	RO	No		Micro-seconds
1208	Float32	Analog Input Ch 1	RO	No		Milli-amps
1210	Float32	Analog Input Ch 2	RO	No		Milli-amps
1212	Float32	Analog Input Ch 3	RO	No		Milli-amps
1214	Float32	Analog Input Ch 4	RO	No		Milli-amps
1216	Float32	Analog Input Ch 5	RO	No		Milli-amps
1218	Float32	Analog Input Ch 6	RO	No		Milli-amps
1220	Float32	Analog Input Ch 7	RO	No		Milli-amps
1222	Float32	Analog Input Ch 8	RO	No		Milli-amps
1224	Float32	Approximate Board Temperature	RO	No		$^{\circ}$ Celcius
1226	Float32	Factory use only	RO	No		N/A
1228	Float32	Factory use only	RO	No		N/A
1230	Float32	Densitometer Pressure @4mA	RWP	Yes		User Defined
1232	Float32	Densitometer Pressure @20mA	RWP	Yes		User Defined
1234	Float32	Pressure Correction Output	RO	No		User Defined

6.2 Newflow Modbus Master Simulator

There is a configuration file available for the Newflow Modbus Master Simulator. The file is named the PicoRMU_Modbus_Poll_File.xml, and it has three polls defined.

- Poll 1 is for the uint16 registers 1000 to 1018
- Poll 2 is for the uint32 registers 1100 to 1148
- Poll 3 is for the float32 registers 1200 to 1234
- Poll 4 is the write unlock of protected addresses (RWP), register 1000

The screenshot below shows the 16 bit Integer format (uint16, byte order 10) poll response.

The screenshot displays the Newflow Modbus Master Simulator v1.9 interface. The main window shows a table of poll responses for Poll 1, which is configured to read 19 items of type uInt16 from slave address 1 starting at register address 1000. The table lists registers 1000 through 1018 with their corresponding values and descriptions.

Poll	Address	Value	Description
1	1000	0	Function:03 - Read Holding Reg Write Lock
	1001	473	Analog Poll Count
	1002	0	DigIn
	1003	0	DigOut
	1004	0	Invert DigIn
	1005	0	Invert DigOut
	1006	200	Fwd/Rev Tout (100=1sec)
	1007	18392	ID1
	1008	14735	ID2
	1009	64715	ID3
	1010	10300	Firmware Version
	1011	30601	Firmware CRC
	1012	1	Slave Address
	1013	0	Special Function Code
	1014	0	Densitometer Pressure Channel
	1015	1	Densitometer Slave Addr
	1016	451	Densitometer Pressure Register
	1017	6	RS422/485 Config
	1018	300	SS Debounce Period

The configuration panel on the left shows the following settings for Poll 1:

- Sequence: Edit Sequence
- Poll Time: 0.50
- Repeat: 0.0
- Slave Addr: 1
- Reg Addr: 1000
- Addresses / item: 1
- Function: 03 - Read Holding Reg
- # of Items: 19
- Format: uInt16
- Byte Order: 10

The Message Log at the bottom shows the following data:

```

-----Poll: 1-----
(09:55:18.416) Response: 01 03 26 00 00 01 D9 00 00 00 00 00 00 00 00 00 C8 47 D8 39 8F FC CB 28 3C 77 89 00 01 00 00 00 00 01 01 C3 00 06
01 2C 71 AB
(09:55:18.347) Sent: 01 03 03 E8 00 13 84 77
  
```

7 Mechanical Dimensions

The Pico RMU is available in two mechanical mounting arrangements, DIN Rail mounting or potted assembly with 4 screw locations.

For mounting the potted version see the drawing shown below. An optional DIN Rail mounting kit is available for the potted version of the Pico RMU.

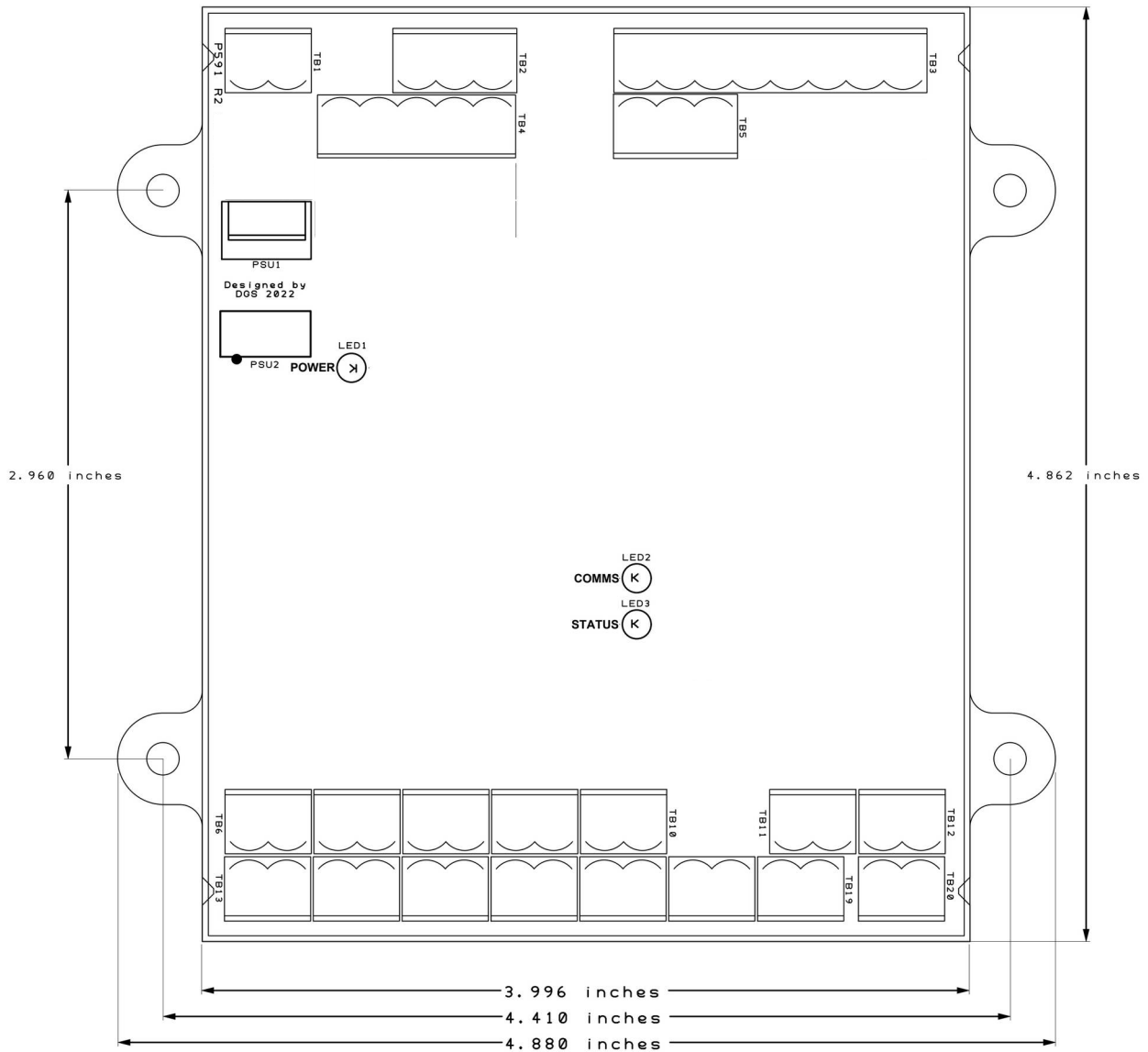

8 Specifications

8.1 Mechanical

8.1.1 DIN Rail Mounted

Length on Rail	4 Inches, (102mm)
Height, including connectors*	2 ½ Inches (64mm)
Width across Rail	5 ¼ Inches (132mm)
Weight	220 grams, including the plug-able connectors
Structure	PVC extrusion
Mounting	35 mm symmetrical Top Hat rail to EN50022 and asymmetric G-type rail to EN50035

8.1.2 Potted Unit

Overall length & width	Approximately 4 7/8 Inches square, (102mm)
Height, including connectors*	1 1/4 Inches (32mm)
Hole Centers	Refer to drawing in 7 - Mechanical Dimensions
Weight	11 ½ oz (325) grams, including the plug-able connectors
Structure	Epoxy potted with metal reinforced mountings
Mounting	#8 gauge screw or a 4 mm screw Supplied with 4 off M4 x 25mm steel screws & lock nuts

8.2 Environmental

Temperature	-40 °F +185 °F operating and storage
Humidity	Up to 95% non-condensing

8.3 Power Supply

Input Voltage & Current	10 V to 30 V D.C. 250 mW typical Suitable for 12 V Solar powered systems
Maximum Input Ripple	2 V peak to peak at 60 Hz
Input protection	200 mA Resettable Input Fuse

* Additional height must be allowed for the cables that emerge vertically from the Pico RMU.

8.4 Digital Status Inputs

Configuration	Individually opto-isolated inputs
Maximum Input Voltage	30 V
Minimum Input on Voltage	5 V
Maximum Input off Voltage	1.5 V
Input Impedance	15 K Ohm typical
Protection	Surge and reverse voltage protection

8.5 Digital Status Outputs

Configuration	Individually Galvanically isolated
Max Output Current	200 mA
Max Output Saturation Voltage	0.5 V @ 200 mA (0.25 V @ 100 mA)
Max Output Standoff Voltage	32V, limited by input protection
Power Off State	All digital outputs Open (Off)
Initial Power on State	All digital outputs Open (Off)
Reverse Protection	Note, current will flow if reverse connected

8.6 Meter Pulse Inputs & Period Measurement

Input Type	Channels A, B & C suitable for meter pulses or densitometer
Configuration	Opto-coupled inputs
Input signal levels	4 V to 24 V
Input current minimum	1.5 mA
Input Impedance	3 K Ohm
Frequency range	DC to 15 KHz
Accuracy of Master Clock	2.5 ppm
Period resolution	1.6 nSec @ 1KHz

8.7 Analog Inputs

Type of Inputs	4-20 mA nominal input type
Conversion Method	24 bit Sigma-Delta ADC
Effective resolution	More than 18 bits, auto zero, auto calibrate
Conversion time	100 mSec per channel
Series mode rejection	Notch filter at 50 Hz and 60 Hz

9 Revision History

Rev	Date	Changes	Prepared	Checked	Authorized
0	1 Jun 2022	Initial Version	MOB	DGS	MOB
1	1 Jul 2022	Added Isolated RS422 wiring	MOB	DGS	MOB
2	4 Aug 2022	Added additional loop drawings and Modbus map	MOB	GPL	MOB
3	3 Oct 2022	Added Potted unit information ARN352	MOB	DGS	MOB
4	5 May 2023	Added Pressure Correction for Density meters Firmware Version: 1v00r07	MOB	DGS	MOB
5	22 Mar 2024	Updated Modbus Map to match new firmware Firmware Version: 1v03r00 [7789]	GPL	MOB	MOB

End of Document
